

Thunderbolt® 160 and 210

Stick Welding Power Source 

Quick Specs

Light Industrial Applications

Garage/job shops
Farm/ranch
Maintenance repair
Light production-line work
Shipyards install/repair

Process* DC stick (SMAW)

Input Power 1-phase power

Max. Open-Circuit Voltage

160: 91 V

210: 85 V

Amperage Range

160: 20–80 A (120 V)

20–160 A (240 V)

210: 25–210 A (240 V)

Maximum Mild Steel Thickness

160: 1/8 in. (120 V)

3/8 in. (240 V)

210: 1/2 in. (240 V)

Best-of-class dependable, portable, powerful stick welder.

Nearly 100 pounds lighter so you can work smarter not harder by bringing the welder to the work. It's portable so it's easier to carry and store.

More powerful — up to 85 more amps — compared to leading competitive machine means you can weld thicker materials.

Hot Start™ technology provides easy, quick and reliable arc starts.

Precise, accurate, infinite amperage control and heat output.

Thunderbolt 160 model features dual voltage with **multi-voltage plug (MVP™)**. Allows for connection to 120- or 240-volt receptacles without tools. Choose the plug that fits the receptacle and connect it to the power cord.

Comes with:

- 10 ft. (3 m) No. 4 electrode cable with heavy-duty electrode holder
- 10 ft. (3 m) work cable with clamp
- 6.5 ft. (2 m) power cord with MVP™ plugs for 120 V and 240 V (160 model) **OR** 240 V plug (210 model)
- Cable pouch



Thunderbolt 160 shown.

 **120 or 240 V**
INPUT POWER

Thunderbolt 160 only

 **NEARLY 100 lb. LIGHTER**
AND MORE POWER

Compared to leading competitive machine

Specifications (Subject to change without notice.)

CC **DC** **1**
Phase

Model	Input Power	Welding Amperage Range	Rated Output	Amps Input at Rated Output	Max. Open-Circuit Voltage	Dimensions	Net Weight
Thunderbolt 160	120 V, 50/60 Hz	20–80 A	65 A at 20% duty cycle	20.7	91 V	H: 10.5 in. (267 mm) W: 7.125 in. (181 mm) D: 13.375 in. (340 mm)	15 lb. (6.8 kg)
	240 V, 50/60 Hz	20–160 A	160 A at 30% duty cycle	27.8			
Thunderbolt 210	240 V, 50/60 Hz	25–210 A	210 A at 20% duty cycle	43.4	85 V		15.5 lb. (7.0 kg)



TRUE BLUE
3YR. WARRANTY

ГАРАНТИЯ НА ОБОРУДОВАНИЕ 3 ГОДА

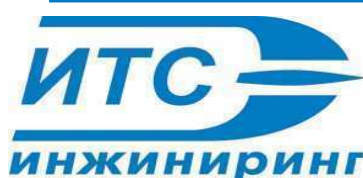

ОФИЦИАЛЬНЫЙ ДИСТРИБЬЮТОР
MILLER ELECTRIC В РОССИЙСКОЙ ФЕДЕРАЦИИ

ПРОФЕССИОНАЛЬНЫЕ РЕШЕНИЯ
ДЛЯ СВАРКИ И РЕЗКИ

ООО " ИТС-ИНЖИНИРИНГ"
+7(495) 660 62 72

г. МОСКВА
ул. КОПТЕВСКАЯ д. 73А стр 7



www.topweldcut.ru

Control Panel

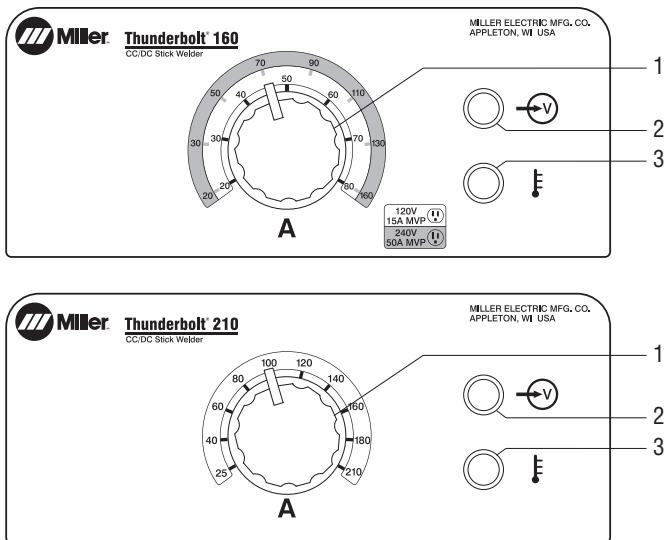

1. Amperage Adjustment Control
2. Power Indicator Light
3. Overtemperature Light

Electrode Charts

Electrode Polarity Chart

Electrode	DC*	AC	Position	Penetration	Usage
6010	EP	—	All	Deep	Min. prep, rough, high spatter
6011	EP	✓	All	Deep	
6013	EP, EN	✓	All	Low	General
7014	EP, EN	✓	All	Med.	Smooth, easy, fast
7018	EP	✓	All	Low	Low hydrogen, strong
7024	EP, EN	✓	Flat horiz. fillet	Low	Smooth, easy, faster
Ni-Ci	EP	✓	All	Low	Cast iron
308L	EP	✓	All	Low	Stainless

* EP = Electrode positive (reverse polarity)
EN = Electrode negative (straight polarity)

Electrode/Amperage Chart

Electrode	Diameter		Amperage Range			
	in.	mm	Min. 50 A	100 A	150 A	200 A Max.
6010 and 6011	3/32	2.4				
	1/8	3.2				
	5/32	4.0				
6013	3/16	4.8				
	1/16	1.6				
	5/64	2.0				
	3/32	2.4				
	1/8	3.2				
7014	5/32	4.0				
	3/16	4.8				
	3/32	2.4				
7018	1/8	3.2				
	5/32	4.0				
	3/32	2.4				
7024	1/8	3.2				
	5/32	4.0				
	3/32	2.4				
Ni-Ci	1/8	3.2				
	5/32	4.0				
	3/16	4.8				
308L	3/32	2.4				
	1/8	3.2				
	5/32	4.0				

Ideal performance for most 6010, 6011, 6013 and 7018 rods.

Note: 6010 not recommended for open root welding.

Thunderbolt 160

120 V: 1/16–1/8 in. (some limitations with 3/32-inch rods and very limited with 1/8-inch rods based on rod/amperage)

240 V: 1/16–5/32 in. (some limitations with 5/32-inch rods based on amperage)

Thunderbolt 210

1/16–3/16 in. (some limitations with 3/16-inch rods based on amperage)

Typical Installation (DCEP)

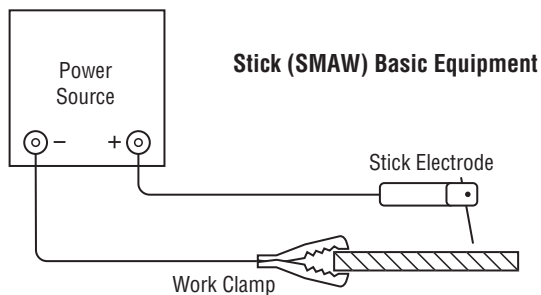

Note: Also DCEN polarity capable.

Performance Data

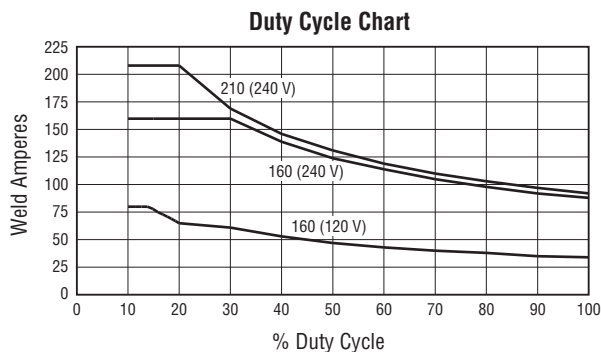

* DC TIG capable.

Ordering Information

Power Source	Stock No.	Description	Qty.	Price
Thunderbolt® 160	907721	Single-phase, 120 and 240 V		
Thunderbolt® 210	907722	Single-phase, 240 V		
Accessories				
Stick Electrodes		See charts above		
Helmet/Gloves/Scratch Brush				
Chipping Slag Hammer				
Wall Receptacle				

MILLER рекомендует

elga

сварочные материалы

ИТС
ИНЖИНИРИНГ

ОФИЦИАЛЬНЫЙ ДИСТРИБЬЮТОР
MILLER ELECTRIC В РОССИЙСКОЙ ФЕДЕРАЦИИ

ПРОФЕССИОНАЛЬНЫЕ РЕШЕНИЯ
ДЛЯ СВАРКИ И РЕЗКИ

ООО " ИТС-ИНЖИНИРИНГ"
+7(495) 660 62 72

г. МОСКВА
ул. КОПТЕВСКАЯ д. 73А стр 7



www.topweldcut.ru

